

this drawing is the property of RAPITECH srl - it may not be reproduced or transmitted to third parties without the authorization of RAPITECH srl

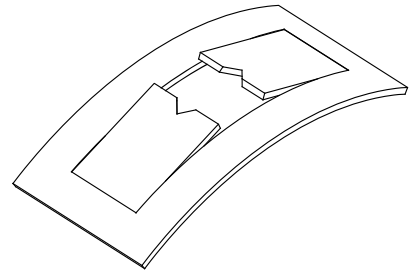
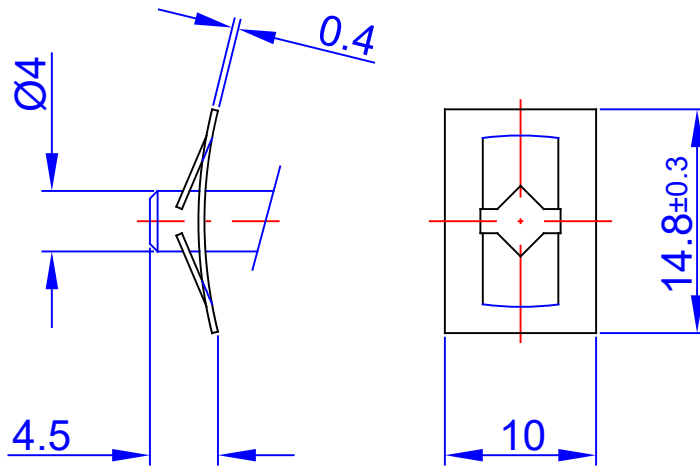

	<b>NOT OK</b>	<b>SI RACCOMANDA DI UTILIZZARE SEMPRE PERNI ARROTONDATI</b>
	<b>OK</b>	<b>IT IS RECOMMENDED TO USE ALWAYS ROUNDED EDGE SHAFT</b>

finitura standard - tempratura e rinvenimento + olio anticorrosivo | standard finishing: hardened and tempered + anticorrosive oil

MODIFICATION	DATE	DESCRIPTION	SIGN																																
<table border="1"> <tr> <td colspan="4"><b>PART NAME</b></td> </tr> <tr> <td colspan="4">Fissatore rettangolare - perni Ø 4,0 mm Rectangular quicklock washer (push on fixes) - pin Ø 4,0 mm</td> </tr> <tr> <td><b>PART NUMBER</b></td> <td><b>DRAW ID</b></td> <td><b>WEIGHT</b></td> <td><b>TOLLERANCE</b></td> </tr> <tr> <td>RPR 1.040.15.10</td> <td>RPR1008</td> <td>0,43 gr</td> <td>± 0.1</td> </tr> <tr> <td><b>RAW MATERIAL</b></td> <td colspan="2"><b>HEAT TREATMENT</b></td> <td><b>HARDNESS</b></td> </tr> <tr> <td>EN 1.1231/C67S (EN 10132-4)</td> <td colspan="2">Hardened and tempered</td> <td>HR15N: 82±84</td> </tr> <tr> <td><b>DESIGNED:</b> S.V.</td> <td><b>DATE:</b> 17/09/2008</td> <td colspan="2"><b>REPLACES:</b> .</td> </tr> <tr> <td><b>APPROVED:</b> L.P.</td> <td><b>DATE:</b> 17/09/2008</td> <td colspan="2"><b>REPLACED BY:</b> .</td> </tr> </table>				<b>PART NAME</b>				Fissatore rettangolare - perni Ø 4,0 mm Rectangular quicklock washer (push on fixes) - pin Ø 4,0 mm				<b>PART NUMBER</b>	<b>DRAW ID</b>	<b>WEIGHT</b>	<b>TOLLERANCE</b>	RPR 1.040.15.10	RPR1008	0,43 gr	± 0.1	<b>RAW MATERIAL</b>	<b>HEAT TREATMENT</b>		<b>HARDNESS</b>	EN 1.1231/C67S (EN 10132-4)	Hardened and tempered		HR15N: 82±84	<b>DESIGNED:</b> S.V.	<b>DATE:</b> 17/09/2008	<b>REPLACES:</b> .		<b>APPROVED:</b> L.P.	<b>DATE:</b> 17/09/2008	<b>REPLACED BY:</b> .	
<b>PART NAME</b>																																			
Fissatore rettangolare - perni Ø 4,0 mm Rectangular quicklock washer (push on fixes) - pin Ø 4,0 mm																																			
<b>PART NUMBER</b>	<b>DRAW ID</b>	<b>WEIGHT</b>	<b>TOLLERANCE</b>																																
RPR 1.040.15.10	RPR1008	0,43 gr	± 0.1																																
<b>RAW MATERIAL</b>	<b>HEAT TREATMENT</b>		<b>HARDNESS</b>																																
EN 1.1231/C67S (EN 10132-4)	Hardened and tempered		HR15N: 82±84																																
<b>DESIGNED:</b> S.V.	<b>DATE:</b> 17/09/2008	<b>REPLACES:</b> .																																	
<b>APPROVED:</b> L.P.	<b>DATE:</b> 17/09/2008	<b>REPLACED BY:</b> .																																	

